

# OUTDOOR SPLIT SYSTEM HEAT PUMP

## USER'S INFORMATION / INSTALLATION INSTRUCTIONS

### TWO - STAGE | R-410A | 16 SEER MODELS

#### ABOUT THE HEAT PUMP

Your heat pump is a unique, all weather comfort-control appliance that will heat and cool your home year round and provide energy saving comfort. It's an unknown fact that heat is always in the air, even when the outside temperature is below freezing. The heat pump uses this basic law of physics to provide energy saving heat during the winter months. For example, If the outdoor temperature is 47° F (8° C), your heat pump can deliver approximately 3.5 units of heat energy per each unit of electrical energy used, as compared to a maximum of only 1 unit of heat energy produced with conventional heating systems.

In colder temperatures, the heat pump performs like an air conditioner run in reverse. Available heat energy outside the home is absorbed by the refrigerant and exhausted inside the home. This efficient process means you only pay for "moving" the heat from the outdoors to the indoor area. You do not pay to generate the heat, as with more traditional furnace designs.

During summer, the heat pump reverses the flow of the heat-absorbing refrigerant to become an energy-efficient, central air conditioner. Excess heat energy inside the home is absorbed by the refrigerant and exhausted outside the home.

#### HEAT PUMP MAINTENANCE

##### CAUTION:

**Shut off all electrical power to the unit before performing any maintenance. Failure to comply may result in personal injury or death.**

Proper maintenance is most important to achieve the best performance from the appliance and should be performed by a qualified service technician at least once a year. Read the maintenance items below and follow the instructions for years of safe, trouble free operation.

##### Regular Cleaning

##### WARNING:

**Do not place combustible material on or against the unit cabinet. Do not place combustible materials, including gasoline and any other flammable vapors and liquids, in the vicinity of the unit.**

- Clean or replace the indoor air filter at the start of each heating and cooling season, and when an accumulation of dust and dirt is visible on the air filter.
- Remove any leaves and grass clippings from around the coil of the outdoor unit, being careful not to damage the aluminum fins.
- Check and remove any obstructions, such as twigs, sticks, etc.

#### WARRANTY INFORMATION

A warranty certificate with full details is included with the heat pump. Carefully review these responsibilities with your dealer or service company. The manufacturer will not be responsible for any costs found necessary to correct problems due to improper setup, improper installation, adjustments, improper operating procedure on the part of the user, etc.

Some specific examples of service calls which are not included in the limited warranty are:

- Correcting wiring problems in the electrical circuit supplying the heat pump.
- Resetting circuit breakers or other switches.
- Adjusting or calibrating of thermostat.

#### IMPORTANT

**Please read this information thoroughly and become familiar with the capabilities and use of your appliance before attempting to operate or maintain this unit. Keep this literature where you have easy access to it in the future. If a problem occurs, check the instructions and follow recommendations given. If these suggestions don't eliminate the problem, call your servicing contractor.**

**The Installation Instructions are primarily intended to assist qualified individuals experienced in the proper installation of this appliance. Some local codes require licensed installation/service personnel for this type of equipment. Please read all instructions carefully before starting the installation.**

**DO NOT DESTROY! PLEASE READ CAREFULLY & KEEP IN A SAFE PLACE FOR FUTURE REFERENCE**

# USER'S INFORMATION

## OPERATING INSTRUCTIONS

Please refer to the thermostat manufacturer's User manual for detailed programming instructions.

### Cooling Operation Only

1. Set the thermostat's system mode to COOL or AUTO and change the fan mode to AUTO. See Figure 1
2. Set the temperature selector to the desired temperature level. The outdoor fan, compressor, and blower motor will all cycle on and off to maintain the indoor temperature at the desired cooling level.

**NOTE:** If the temperature level is re-adjusted, or the system mode is reset, the fan and compressor in the outdoor unit may not start immediately. A protective timer circuit holds the compressor and the outdoor fan off for approximately three minutes following a previous operation or the interruption of the main electrical power.

### Heating Operation Only

1. Set the thermostat's system mode to HEAT or AUTO and change the fan mode to AUTO. See Figure 1.
2. Set the temperature selector to the desired temperature level. The compressor, outdoor fan, and blower motor will cycle on and off to maintain the indoor temperature at the desired heating level.

**NOTE:** If the temperature level is re-adjusted, or the system mode is reset, the fan and compressor in the outdoor unit may not start immediately. A protective timer circuit holds the compressor and the outdoor fan off for approximately three minutes following a previous operation or the interruption of the main electrical power.

### Emergency Heat

Some thermostats may include a system mode called EM HT or AUX HT, etc. This is a back-up heating mode that should only be used if a problem is suspected. With the mode set to EM HT, etc., the compressor and outdoor fan will be locked off and supplemental heat (electric resistance heating) will be used as a source of heat. Sustained use of electric resistance heat in place of the heat pump will result in an increase in electric utility costs.

### Defrost Operation

During cold weather heating operation, the outdoor unit will develop a coating of snow and ice on the heat transfer coil. This is normal and the unit will defrost itself. This unit features Adaptive Demand Defrost that monitors ambient and coil temperatures to regulate the defrost function accordingly.

At the beginning of the defrost cycle, both the outdoor condenser fan and compressor will turn off. After approximately 30 seconds, the compressor will turn on

and begin to heat the outdoor coil causing the ice and snow to melt. **NOTE:** While the ice and snow is melting, some steam may rise from the outdoor unit as the warm coil causes the melting frost to evaporate. When defrost is completed, the outdoor fan motor will start, and the compressor will turn off again. In approximately 30 seconds the compressor will start up again and continue normal operation.

### Operating the Heat Pump for Automatic Cooling & Heating

1. Set the thermostat system switch to AUTO and the thermostat fan switch to AUTO. See Figure 1.

**NOTE:** Thermostats will vary. Some models will not include the AUTO mode, and others will have the AUTO in place of the HEAT and COOL, and some will include all three.

2. Set the thermostat temperature to the desired heating and cooling temperature level(s). The outdoor unit and the indoor blower will then cycle on and off in either the heating or cooling mode of operation as required to automatically maintain the indoor temperature within the desired limits.

### Operating the Indoor Blower Continuously

The continuous indoor blower operation is typically used to circulate the indoor air to equalize a temperature unbalance due to a sun load, cooking, or fireplace operation.

Set the thermostat fan mode to ON (Figure 1). The indoor blower starts immediately, and will run continually until the fan mode is reset to AUTO.

The continuous indoor blower operation can be obtained with the thermostat system mode set in any position, including OFF.

### Shutting the Heat Pump Off

Change the thermostat's system mode to OFF and the fan mode to AUTO. See Figure 1. **NOTE:** The system will not operate, regardless of the temperature selector setting.

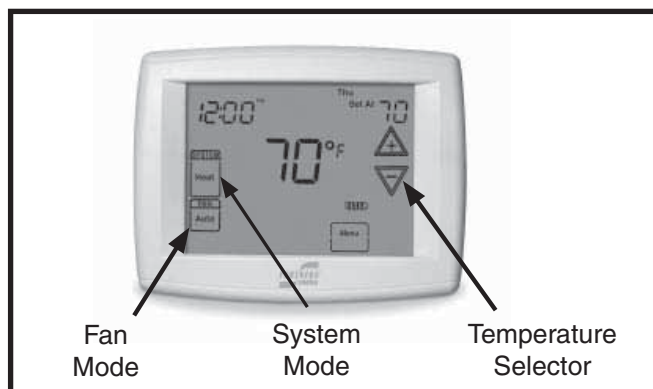

Figure 1. Digital Thermostat

# INSTALLER INFORMATION ONLY

<b>Important Safety Information</b> .....4	<b>Adjustment of Refrigerant Charge</b> .....9
Pressures Within the System .....4	Charging an R-410A System in AC Mode at
Labels, Tags, and Precautions .....4	Outdoor Temperatures above 55° F ..... 10
Braze Operations.....4	Charging an R-410A Unit in Heat Mode ..... 10
<b>Heat Pump Installation</b> .....5	Short Cycle Protection ..... 10
General Information.....5	Defrost Cycle Control ..... 10
Before You Install this Unit.....5	Defrost Test Procedure..... 11
Locating the Heat Pump.....5	Anti Short Cycle Timer Test..... 11
Packaging Removal.....5	Heating Mode..... 11
Ground Level.....5	Cooling Mode..... 11
Connecting Refrigerant Tubing between the	Optional Equipment..... 11
Indoor & Outdoor Unit .....6	Component Functions ..... 11
<b>Electrical Wiring</b> .....6	<b>Component Functions</b> ..... 11
Pre - Electrical Checklist .....6	<b>Replacement Parts</b> ..... 11
Line Voltage.....6	<b>Unit Dimensions</b> ..... 12
Grounding.....7	Figure 6. Unit Dimensions ..... 12
Thermostat Connections .....7	<b>Cooling Charging Charts</b> ..... 13
Outdoor Unit Connections.....7	Figure 7. Cooling Chart for 2 Ton Units ..... 13
Control Circuit Wiring .....7	Figure 8. Cooling Chart for 3 Ton Units ..... 13
Comfort Alert™ Diagnostics Module.....7	Figure 9. Cooling Chart for 4 Ton Units ..... 14
24VAC Power Wiring .....8	Figure 10. Cooling Chart for 5 Ton Units ..... 14
Thermostat Demand Wiring .....8	<b>Heating Charging Chart</b> ..... 15
Interpreting the Diagnostic LED's.....8	Figure 11. Heating Chart ..... 15
LED Description .....8	<b>Wiring Diagrams</b> ..... 16
Outdoor Fan Motor .....8	Figure 12. Standard Models (2 Ton) ..... 16
Optional Equipment.....8	Figure 13. Standard Models (3 Ton) ..... 17
Transformer Upgrade Kit .....8	Figure 14. Standard Models (4 & 5 Ton)..... 18
<b>Startup &amp; Adjustments</b> .....9	Figure 15. Premium / Ultra Models (2,4,5 Ton)..... 19
Pre - Start Checklist .....9	Figure 16. Premium / Ultra Models (3 Ton).....20
Startup-Procedures .....9	<b>Comfort Alert Troubleshooting Charts</b> ..... 21
Air Circulation - Indoor Blower .....9	Table 4. LED Diagnostics ..... 21
System Heating.....9	Table 5. Module Wiring Troubleshooting ..... 23
System Cooling .....9	

## IMPORTANT SAFETY INFORMATION

INSTALLER: Please read all instructions before servicing this equipment. Pay attention to all safety warnings and any other special notes highlighted in the manual. Safety markings are used frequently throughout this manual to designate a degree or level of seriousness and should not be ignored. **WARNING** indicates a potentially hazardous situation that if not avoided, could result in personal injury or death. **CAUTION** indicates a potentially hazardous situation that if not avoided, may result in minor or moderate injury or property damage.

---

### **WARNING:**

---

Shut off all electrical power to the unit before performing any maintenance or service on the system. Failure to comply may result in personal injury or death.

---

---

### **WARNING:**

---

Unless noted otherwise in these instructions, only factory authorized parts or accessory kits may be used with this product. Improper installation, service, adjustment, or maintenance may cause explosion, fire, electrical shock or other hazardous conditions which may result in personal injury or property damage

---

---

### **WARNING:**

---

Split System Heat Pumps leave the factory with a nitrogen holding charge. Follow all charging instructions for maximum unit performance and efficiency. Some local codes require licensed installation/service personnel to service this type of equipment. Refrigerant charging must be done by qualified personnel familiar with safe and environmentally responsible refrigerant handling procedures. Under no circumstances should the owner attempt to install and/or service this equipment. Failure to comply with this warning could result in property damage, personal injury, or death.

---

---

### **CAUTION:**

---

This unit uses refrigerant R-410A. DO NOT use any other refrigerant in this unit. Use of another refrigerant will damage the unit.

---

---

### **WARNING:**

---

The information listed below must be followed during the installation, service, and operation of this unit. Unqualified individuals should not attempt to interpret these instructions or install this equipment. Failure to follow safety recommendations could result in possible damage to the equipment, serious personal injury or death.

---

- The installer must comply with all local codes and regulations which govern the installation of this type of equipment. Local codes and regulations take precedence over any recommendations contained in these instructions. Consult local building codes and the National Electrical Code (ANSI CI) for special installation requirements.
- All electrical wiring must be completed in accordance with local, state and national codes and regulations and with the National Electric Code (ANSI/NFPA 70) or in Canada the Canadian Electric Code Part 1 CSA C.22.1.
- This equipment contains liquid and gaseous refrigerant under high pressure. DO NOT USE ANY PORTION OF THE CHARGE FOR PURGING OR LEAK TESTING. Installation or servicing should only be performed by qualified trained personnel thoroughly familiar with this type equipment.
- Fully annealed, refrigerant grade copper tubing should be used when installing the system. Refrigerant suction line tubing should be fully insulated.
- Installation of equipment may require brazing operations. Installer must comply with safety codes and wear appropriate safety equipment (safety glasses, work gloves, fire extinguisher, etc.) when performing brazing operations.
- This unit is designed for outdoor installations only and should be located as described on page 6.
- Follow all precautions in the literature, on tags, and on labels provided with the equipment. Read and thoroughly understand the instructions provided with the equipment prior to performing the installation and operational checkout of the equipment.

## HEAT PUMP INSTALLATION

### General Information

The JT4BF series Heat Pump is designed only for outdoor rooftop or ground level installations. This unit has been tested for capacity and efficiency in accordance with A.H.R.I. Standards and will provide many years of safe and dependable comfort, providing it is properly installed and maintained. Abuse, improper use, and/or improper maintenance can shorten the life of the appliance and create unsafe hazards.

To achieve optimum performance and minimize equipment failure, it is recommended that periodic maintenance be performed on this unit. The ability to properly perform maintenance on this equipment requires certain mechanical skills and tools.

### Before You Install this Unit

- ✓ The cooling load of the area to be conditioned must be calculated and a system of the proper capacity selected. It is recommended that the area to be conditioned be completely insulated and vapor sealed.
- ✓ Check the electrical supply and verify the power supply is adequate for unit operation. The system must be wired and provided with circuit protection in accordance with local building codes. If there is any question concerning the power supply, contact the local power company.
- ✓ The indoor section (air handler, furnace, etc) should be installed before routing the refrigerant tubing. Refer to the indoor unit's installation instructions for installation details.
- ✓ All units are securely packed at the time of shipment and upon arrival should be carefully inspected for damage prior to installing the equipment at the job site. Verify coil fins are straight. If necessary, comb fins to remove flattened or bent fins. Claims for damage (apparent or concealed) should be filed immediately with the carrier.
- ✓ Please consult your dealer for maintenance information and availability of maintenance contracts. Please read all instructions before installing the unit.

### Locating the Heat Pump

- Survey the job site to determine the best location for mounting the outdoor unit. See Figure 6 (page 12) for unit dimensions.
- Overhead obstructions, poorly ventilated areas, and areas subject to accumulation of debris should be avoided.
- Sufficient clearance for unobstructed airflow through the outdoor coil must be maintained in order to achieve rated performance. See Figure 2 for minimum clearances to obstructions.
- Consideration should be given to availability of electric power, service access, noise, and shade.

### Packaging Removal

To prevent damage to the tubing connections, carefully remove the carton and user's manual from the equipment. Discard the shipping carton.

### Ground Level

Ground level installations must be located according to local building codes or ordinances and these requirements:

- Clearances must be in accordance with those shown in Figure 2.
- A suitable mounting pad (Figure 3) must be provided and separate from the building foundation. The pad must be level and strong enough to support the weight of the unit. The slab height must be a minimum of 2" (5 cm) above grade and with adequate drainage.

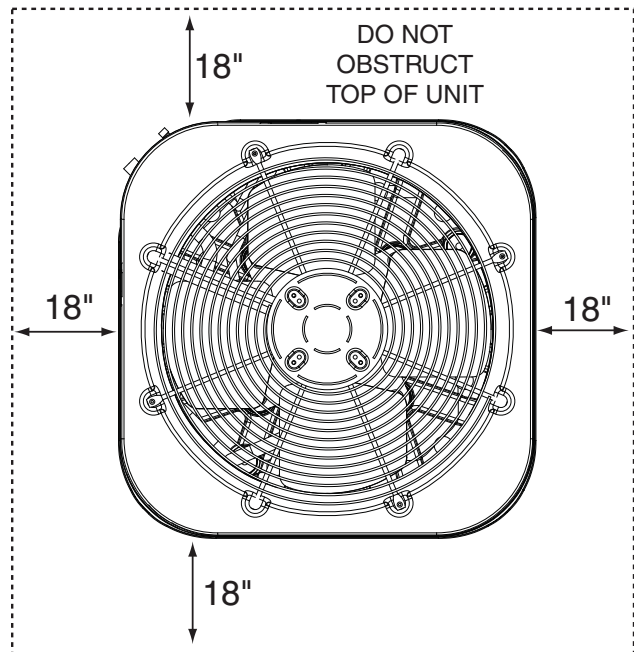

Figure 2. Clearance Requirements

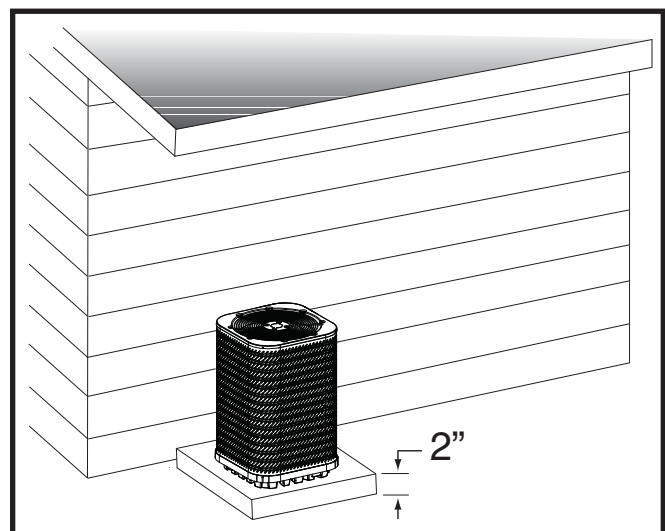

Figure 3. Ground Level Installation

## Connecting Refrigerant Tubing Between the Indoor & Outdoor Unit

### CAUTION:

**This system uses R-410A refrigerant with POE oil. When servicing, cover or seal openings to minimize the exposure of the refrigerant system to air to prevent accumulation of moisture and other contaminants.**

After outdoor and indoor unit placement has been determined, route refrigerant tubing between the equipment in accordance with sound installation practices.

- When connecting refrigerant linesets together, it is recommended that dry nitrogen be flowing through the joints during brazing to prevent internal oxidation and scaling.
- Refrigerant tubing should be routed in a manner that minimizes the length of tubing and the number of bends in the tubing. If precise forming of refrigerant lines is required, a copper tubing bender is recommended. Avoid sharp bends and contact of the refrigerant lines with metal surfaces.
- Refrigerant tubing should be supported in a manner that the tubing will not vibrate or abrade during system operation.
- Tubing should be kept clean of foreign debris during installation.
- Every effort should be made by the installer to ensure that the field installed refrigerant containing components of the system have been installed in accordance with these instructions and sound installation practices to insure reliable system operation and longevity.
- The maximum recommended interconnecting refrigerant line lengths is 75 ft. and the vertical

elevation difference between the indoor and outdoor sections should not exceed 20 ft.

- To maintain the unit's warranty, it is required that a filter drier be installed when the system is open to the atmosphere. This includes, but is not limited to, replacing the evaporator and/or condenser of a system. The filter drier must be installed in strict accordance with the manufacturer's installation instructions.
- Optional equipment such as liquid line solenoid valves, low ambient, etc., should be installed in strict accordance with the manufacturer's installation instructions.

## ELECTRICAL WIRING

### WARNING:

**To avoid risk of electrical shock, personal injury, or death, disconnect all electrical power to the unit before performing any maintenance or service. The unit may have more than one electrical supply.**

**Label all wires prior to disconnection when servicing the unit. Wiring errors can cause improper and dangerous operation.**

- All electrical connections must be in compliance with all applicable local codes and ordinances, and with the current revision of the National Electric Code (ANSI/NFPA 70).
- For Canadian installations the electrical connections and grounding shall comply with the current Canadian Electrical Code (CSA C22.1 and/or local codes).

### Pre-Electrical Checklist

- ✓ Verify that the voltage, frequency, and phase of the supply source match the specifications on the unit rating plate. See Table # (page #).
- ✓ Verify that the service provided by the utility is sufficient to handle the additional load imposed by this equipment. Refer to the unit wiring label for proper voltage wiring.
- ✓ Verify factory wiring is in accordance with the unit wiring diagram or Figures 12 - 16 (pages 16 - 20). Check for loose connections.

### Line Voltage

- A wiring diagram is located on the inside cover of the electrical box of the outdoor unit. The installer should become familiar with the wiring diagram before making any electrical connections to the outdoor unit.
- **An electrical disconnect must be located within sight of and readily accessible to the unit.** This switch shall be capable of electrically de-energizing the outdoor unit.

COPPER WIRE SIZE — AWG (1% Voltage Drop)				
Supply Wire Length-Feet				Supply Circuit Ampacity
200	150	100	50	
6	8	10	14	15
4	6	8	12	20
4	6	8	10	25
4	4	6	10	30
3	4	6	8	35
3	4	6	8	40
2	3	4	6	45
2	3	4	6	50
2	3	4	6	55
1	2	3	4	60

Wire Size based on N.E.C. for 60° type copper conductors.

**Table 1. Copper Wire Size**

- Line voltage to the unit should be supplied from a dedicated branch circuit containing the correct fuse or circuit breaker for the unit. Incoming field wiring and minimum size of electrical conductors and circuit protection must be in compliance with information listed on the outdoor unit data label. Any other wiring methods must be acceptable to authority having jurisdiction.
- The outdoor unit requires both power and control circuit electrical connections. Refer to the wiring diagram / schematic for identification and location of outdoor unit field wiring interfaces or see Figures 12 - 16 (pages 16 - 20). Make all electrical connections in accordance with all applicable codes and ordinances.
- Overcurrent protection must be provided at the branch circuit distribution panel and sized as shown on the unit rating label and according to applicable local codes. See the unit rating plate for minimum circuit ampacity and maximum overcurrent protection limits.
- Provide power supply for the unit in accordance with the unit wiring diagram, and the unit rating plate. Connect the line-voltage leads to the terminals on the contactor inside the control compartment.
- Use only copper wire for the line voltage power supply to this unit as listed in Table 1 (page 6). Use proper code agency listed conduit and a conduit connector for connecting the supply wires to the unit. Use of rain tight conduit is recommended.
- 208/230 Volt units are shipped from the factory wired for 230 volt operation. For 208V operation, remove the lead from the transformer terminal marked 240V and connect it to the terminal marked 208V.

- Optional equipment requiring connection to the power or control circuits must be wired in strict accordance of the NEC (ANSI/NFPA 70), applicable local codes, and the instructions provided with the equipment.

## Grounding

### **WARNING:**

**The unit cabinet must have an uninterrupted or unbroken electrical ground to minimize personal injury if an electrical fault should occur. Do not use gas piping as an electrical ground!**

This unit must be electrically grounded in accordance with local codes or, in the absence of local codes, with the National Electrical Code (ANSI/NFPA 70) or the CSA C22.1 Electrical Code. Use the grounding lug provided in the control box for grounding the unit.

## Thermostat Connections

- Thermostat connections should be made in accordance with the instructions supplied with the thermostat and the indoor equipment.
- The outdoor unit is designed to operate from a 24 VAC Class II control circuit. The control circuit wiring must comply with the current provisions of the NEC (ANSI/NFPA 70) and with applicable local codes having jurisdiction.
- The low voltage wires must be properly connected to the units low voltage terminal block (Figure 4). Recommended wire gauge and wire lengths for typical thermostat connections are listed in Table 2.
- The thermostat should be mounted about 5 feet above the floor on an inside wall. DO NOT install the thermostat on an outside wall or any other location where its operation may be adversely affected by radiant heat from fireplaces, sunlight, or lighting fixtures, and convective heat from warm air registers or electrical appliances. Refer to the thermostat manufacturer's instruction sheet for detailed mounting and installation information.

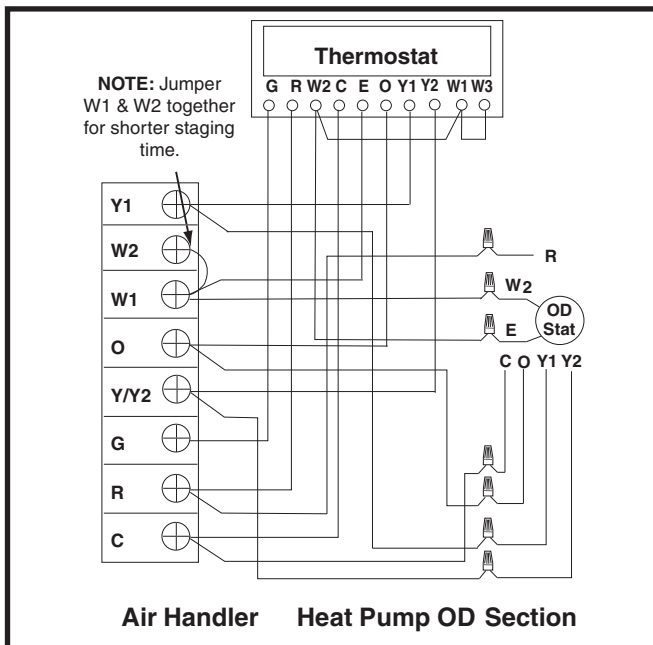

**Figure 4. Typical 2 - Stage Heat Pump w/ Optional Outdoor Thermostat and Variable Speed Air Handler**

## Comfort Alert™ Diagnostics Module (Select Models Only)

The Comfort Alert™ Diagnostics Module (Figure 5, page 8) is a breakthrough innovation for troubleshooting heat pump and air conditioning system failures. The module installs easily in the electrical box of the outdoor unit near the compressor contactor. By monitoring and analyzing data from the Copeland scroll compressor and the thermostat demand, the module can accurately detect the cause of electrical and system related failures without any sensors. A flashing LED indicator communicates the ALERT code and a diagnostic key is also imprinted on the side of the module to quickly direct the technician to the root cause of a problem. **NOTE:** This module does not provide safety protection! The Comfort Alert™ Diagnostics

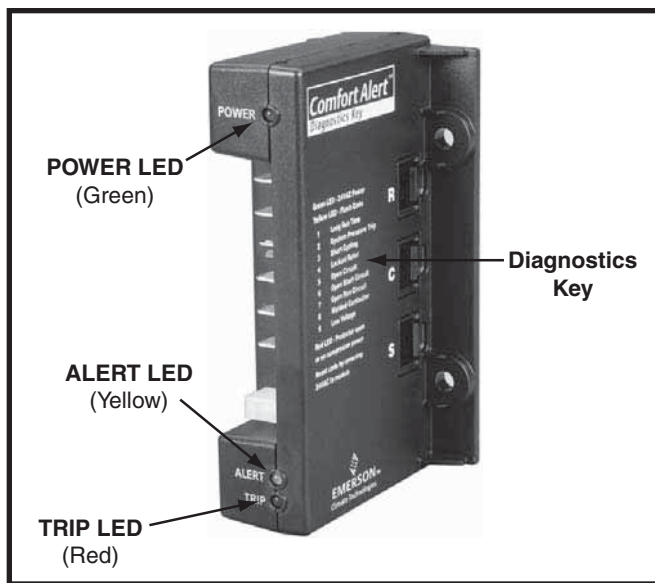

**Figure 5. Comfort Alert™ Diagnostics Module**

Module is a monitoring device and cannot control or shut down other devices.

### 24 VAC Power Wiring

The Comfort Alert™ module requires a constant nominal 24 VAC power supply. The module cannot be powered by the **C** terminal on a defrost board or other control board without experiencing nuisance alerts. **NOTE:** The wiring to the module's **R** & **C** terminals must be routed directly from the indoor unit or thermostat.

If the constant 24 VAC (**R** wire) is not present in the outdoor unit, use one of the spare wires in the thermostat cable to bring power to the module. Connect the other end of the spare wire to **R** at the indoor unit or thermostat.

### Thermostat Demand Wiring

The Comfort Alert™ module requires a thermostat demand signal to operate properly. The thermostat demand signal input (labeled **Y** on the module), should always be connected to the compressor contactor coil. **NOTE:** When the coil is energized, the demand signal input is 24 VAC. When the coil is not energized, the demand signal input should be less than 0.5 VAC.

#### **NOTES:**

- Factory installed modules have different thermostat demand signal wiring. Always follow manufacturer wiring instructions when replacing the module.
- After the thermostat demand signal is connected, verify that 24 VAC across **Y** & **C** when demand is present.

### Interpreting the Diagnostic LED's

When an abnormal system condition occurs, the Comfort Alert™ module displays the appropriate ALERT and/or TRIP LED will flash a number of times consecutively, pause and then repeat the process. To identify a Flash Code number, count the number of consecutive flashes.

Each time the module powers up, the last ALERT Flash Code that occurred prior to shut down is displayed for one minute. The module will continue to display the LED until the condition returns to normal or if 24 VAC power is removed from the module. See Table 4 (page 21) for flash code identification or Table 5 (page 23) for module wiring troubleshooting.

### LED Description

- **POWER LED (Green):** indicates voltage is present at the power connection of the module.
- **ALERT LED (Yellow):** communicates an abnormal system condition through a unique flash code. **NOTE:** The ALERT LED will flash consecutively, pause and then repeat the process. The number of consecutive flashes, referred to as the Flash Code, correlates to a particular abnormal condition. Detailed descriptions of these ALERT Flash Codes are listed in Table 4.
- **TRIP LED (Red):** indicates a demand signal is received from the thermostat, but current to the compressor is not detected by the module. The TRIP LED typically indicates if the compressor protector is open or the compressor has no power.

The scroll compressor's **R** (run), **C** (common), and **S** (start) wires are routed through the holes in the Comfort Alert™ module marked **R**, **C**, and **S**.

**NOTE:** The common wire does not need to be routed through the module for it to operate.

### Outdoor Fan Motor

If the unit utilizes a 2-speed condenser fan motor, this motor will operate on low speed when in low cooling, and on high speed when in high cooling. A relay within the control area switches the fan motor from low to high speed using the call for high cooling as the trigger. Other models that utilize BLDC fixed torque variable speed fan motors will not require a relay.

### Optional Equipment

Optional equipment requiring connection to the power or control circuits must be wired in strict accordance with current provisions of the NEC (ANSI/NFPA 70), with applicable local codes having jurisdiction, and the installation instructions provided with the equipment. Optional Equipment (low ambient control, hard start kits, etc.) should be installed in strict accordance with the manufacturer's installation instructions

### Transformer Upgrade Kit

If this 2-stage heat pump is installed in conjunction with a gas furnace and fossil fuel kit, the furnace transformer **MUST** be upgraded to one with a 60 VA rating or using the transformer upgrade kit (904077). To upgrade the transformer:

- Remove the existing transformer and install the new 60 VA transformer.
- Remove the 3 amp fuse on the furnace control board and install the 5 amp fuse provided.



**NOTE:** The new transformer may be larger than the existing transformer that is mounted in the furnace. If this happens, mount the 60 VA transformer using one of the mounting holes in the furnace panel. On the other side either drill a 0.149 hole in the panel and use the existing fastener, or use a self-drilling fastener to secure the other side of the transformer.

## START UP & ADJUSTMENTS

### Pre-Start Check List

- √ Verify the indoor unit is level and allows proper condensate drainage.
- √ Verify the outdoor coil and top of the unit are free from obstructions and debris, and all equipment access/control panels are in place.
- √ Verify air filters are cleaned and properly installed.
- √ Verify duct work is sealed to prevent air leakage.
- √ Verify line voltage power leads are securely connected and the unit is properly grounded.
- √ Verify low voltage wires are securely connected to the correct leads on the low voltage terminal strip.
- √ Verify power supply branch circuit overcurrent protection is sized properly.
- √ Verify the thermostat is wired correctly.

### Start-Up Procedures

The thermostat's function mode should be set to OFF and the fan mode should be set to AUTO. Close all electrical disconnects to energize the system.

### Air Circulation - Indoor Blower

---

#### **CAUTION:**

---

**These units have a crankcase heater factory installed. Wait 24 hours prior to startup to allow for heating of the compressor crankcase. Failure to comply may result in damage and could cause premature failure of the system.**

1. Set the thermostat system mode on OFF and the fan mode to ON.
2. Verify the blower runs continuously. Check the air delivery at the supply registers and adjust register openings for balanced air distribution. If insufficient air is detected, examine ductwork for leaks or obstructions.
3. Set the thermostat fan mode to AUTO and verify the blower stops running.

### System Cooling

1. Set the thermostat's system mode to COOL and the fan mode to AUTO. Gradually lower the thermostat temperature setpoint below room temperature and verify the outdoor unit and indoor blower energize.
2. Verify blower wheel is spinning in direction indicated by arrow. Feel the air being circulated by the indoor blower and verify that it is cooler than ambient temperature. Listen for any unusual noises. If unusual sounds occur,

determine the source of the noise and correct as necessary.

3. Verify HI and LO refrigerant pressures.
4. Allow the system to operate for several minutes and then set the temperature selector above room temperature. Verify the fan and compressor cycle off with the thermostat. **NOTE:** The blower should also stop unless fan mode is set to the ON position.

### System Heating (optional)

1. If heating equipment (furnace, air handler) is provided with the system, lower the thermostat setpoint temperature to the lowest temperature setting and change the thermostat's system mode to HEAT.
2. Gradually increase the thermostat's setpoint temperature to the maximum setting.
3. Verify the optional heating equipment (furnace or electric heat) and indoor blower energize. Feel the air being circulated by the indoor blower and verify that it is warmer than ambient temperature. Listen for any unusual noises. If unusual sounds occur, determine the source of the noise and correct as necessary.

**NOTE:** Other sources for heating (electric furnace, fossil fuel furnace, air handler with electric heat options, etc.) that interface with the heat pump should be functionally checked to verify system operation and compatibility with the heat pump. Refer to the installation instructions for this equipment and perform a functional checkout in accordance with the manufacturer's instructions.

### Adjustment of Refrigerant Charge

---

#### **CAUTION:**

---

**Split system equipment contains liquid and gaseous refrigerant under pressure. Adjustment of refrigerant charge should only be attempted by qualified, trained personnel thoroughly familiar with the equipment. Under no circumstances should the homeowner attempt to install and/or service this equipment. Failure to comply with this warning could result in equipment damage, personal injury, or death.**

#### **NOTES:**

- The unit must be charged while both first and second stages are operating.
- To achieve rated capacity and efficiency the compressor must be exposed to refrigerant for at least 24 hours prior to running and then must be run for a minimum of 12 hours.
- The Refrigerant Charging Charts (Figures 7 - 11, pages 13 - 15) are applicable to listed assemblies of equipment and at listed airflows for the indoor coil. Assemblies of indoor coils and outdoor units not listed are not recommended. To properly charge these units:

1. Read all Installation Instructions first.
2. Complete any brazing operations. (e.g. Split system line-sets)
3. Leak check and evacuate the whole system using proper methods.
4. Purge the nitrogen holding charge.
5. Evacuate the unit to 350-500 microns.
6. Allow the unit to remain under vacuum for at least 30 min.
7. Weigh-In the proper amount of new (or reclaimed) R-410A refrigerant. Refer to Table 2 or the units rating label to determine the correct amount of charge.
  - Refrigerant charging charts are applicable only to matched assemblies of NORDYNE equipment and listed airflows for the indoor coil. Refer to Figures 7 - 10 (pages 13 - 14) and Table 2 for correct system charge.
  - JT5BD outdoor units with indoor coils not listed are not recommended. Deviations from rated airflows or non-listed combinations may require modification to the expansion device and refrigerant charging procedures for proper and efficient system operation.
  - The refrigerant charge can be checked and adjusted through the service ports provided external to the outdoor unit. Use only gage line sets which have a "Schrader" depression device present to actuate the valve.

TONNAGE	SYSTEM CHARGE R-410A OZ.
2 Ton	210
3 Ton	272
4 Ton	272
5 Ton	272

**Table 2. Split System Heat Pump Charge**

**Charging an R-410A system in AC mode at outdoor temperatures above 55° F.**

1. With the system operating at steady-state, measure the liquid refrigerant pressure (in psig) at the outdoor unit service valve.
2. Measure the liquid refrigerant temperature (in Fahrenheit) at the service valve.
3. Determine the required liquid refrigerant pressure. Refer to Table 2 for correct system charge.
  - If the pressure measured in Step 1 is greater than the required liquid refrigerant pressure determined in Step 3, then there is too much charge in the system. Remove refrigerant and repeat Steps 1 through 3 until the system is correctly charged.
  - If the pressure measured in Step 1 is less than the required liquid refrigerant pressure determined in Step 3, there is too little charge in the system. Add refrigerant and repeat Steps 1 through 3 until the system is correctly charged.

**Charging an R-410A Unit in Heating Mode.**

1. Evacuate the refrigerant system.
2. Weigh in the proper charge per Table 2, using the Heating Charging Chart (Figure 11, page 15) as a guide. Unit charge MUST be verified in cooling season.
3. Verify the unit is operating properly.

**Short Cycle Protection**

1. With the system operating in COOLING mode, record the setpoint temperature setting of the thermostat.
2. Gradually raise the setpoint temperature until the outdoor unit and indoor blower de-energize.
3. Immediately lower the setpoint temperature of the thermostat to its original setting and verify that the indoor blower is energized and that the outdoor unit remains de-energized.
4. After approximately 3 minutes, verify that the outdoor unit energizes and the temperature of the air supplied to the facility is cooler than ambient temperature.

**Defrost Cycle Control**

The defrost cycle is controlled by an Adaptive Demand Defrost algorithm that monitors coil temperature and ambient temperature. Other features of the of the demand defrost board include:

- 4 Field selectable defrost termination temperatures (50° F - 80° F coil temperature).
- Field selectable compressor delay feature.
- High pressure and low pressure switches.
- Sensing of second stage compressor demand.
- Test/speed up capability.
- Anti short cycle timer (3 minutes) for compressor protection.
- On board diagnostics with flashing LED for quicker troubleshooting. See Table 3.

Control is uncalibrated when power is applied. Calibration occurs after a defrost cycle. The control initiates this sacrificial defrost after 34 minutes of accumulated compressor run time in heating with coil temperature below 35° F. The defrost cycle terminates if coil sensor reaches selected termination temperature or after 14 minutes defrost.

DIAGNOSTIC DESCRIPTION	LED STATUS
Control Fault (No Power)	Off
Normal Operation	On
ASCD Delay Active (with compressor demand)	1 Flash
Low Pressure Switch Lockout	2 Flashes
High Pressure Switch Lockout	3 Flashes
Ambient Sensor Fault	4 Flashes
Coil Sensor Fault	5 Flashes

**Table 3. Control Diagnostic**

Defrost function is disabled if coil temperature is above 35° F. If Ambient sensor is detected as open or shorted, demand defrost will not operate and control will revert to time/temperature defrost operation. If the outdoor coil sensor is detected as open or shorted, the control will not perform demand or time/temperature defrost operation. **NOTE:** When the defrost cycle initiates, there will be a 30 second compressor delay going into and out of the defrost cycle. This delay may be removed by removing **P6** connector on the board.

This 2-stage unit will defrost in second stage regardless of the stage called for by the thermostat.

**NOTE:** All units are shipped from the factory with the default termination temperature set at 70° F.

### Defrost Test Procedure

1. Terminals **R - C** must have 18-30VAC present between them in order for defrost sequences to be initiated.
2. With heat mode thermostat demand (**Y** connected to **R**), short and hold the TEST pins together. This will energize reversing valve to initiate a forced defrost. **NOTE:** This will bypass the ASCD and allow the high stage compressor to come on immediately (if the REMOVE FOR NO DELAY jumper at **P6** is removed). If the REMOVE FOR NO DELAY jumper at **P6** is installed, the compressor will energize immediately following a 30-second delay.
3. Remove the short on the TEST pins.
  - If the Coil temperature is above the Terminate Temperature selection setting, the defrost cycle will be terminated (reversing valve will de-energized).
  - If the coil temperature is below the Terminate Temperature election setting, the defrost cycle will continue for 14 minutes or until the coil temperature rises above the Terminate Temperature selection setting. **NOTE:** Short the TEST pins for 1 second or more to force the control out of defrost and back to heating mode (reversing valve de-energized). Compressor will turn on immediately (if the REMOVE FOR NO DELAY jumper is removed).
  - If the REMOVE FOR NO DELAY jumper is installed, the compressor will energize immediately following a 30-second delay.

**NOTE:** If the Y2 thermostat input is energized (2 - stage system), the second stage will turn on. If the above steps will not initiate a defrost, replace the defrost board.

### Anti Short Cycle Timer Test

The 3-minute time delay feature can be bypassed by shorting the TEST pins together.

### Heating Mode

When the TEST pins are shorted together for more than 1-second, the control will switch between defrost mode and heating mode (as described in the Defrost Test Procedure section).

### Cooling Mode

When the TEST pins are shorted together for more than 1-second, the Anti Short Cycle Timer will be bypassed.

### Optional Equipment

A functional checkout should be performed in accordance with the checkout procedures supplied with the equipment.

## COMPONENT FUNCTIONS

### Comfort Alert™ Diagnostics

The Comfort Alert diagnostics module troubleshoots heat pump and air conditioning system failures and accurately detects the cause of electrical and system related failures without any sensors. A flashing LED indicator communicates the ALERT code to quickly direct the technician to the root cause of a problem.

### Low-Pressure Switch

A low-pressure switch is factory installed and located internally on the suction line of the outdoor unit. The switch is designed to protect the compressor from a loss of charge by interrupting the thermostat inputs to the unit.

If the suction pressure falls below 5 psig, the switch will open and de-energize the outdoor unit. The switch will close again when the suction pressure increases above 20 psig. **NOTE:** When the switch opens and then closes, there is a 3 minute short cycling delay before the outdoor unit will energize. Under normal conditions the switch is closed.

### High-Pressure Switch

A high-pressure switch is factory installed and located internally on the compressor discharge line of the outdoor unit. If the discharge pressure rises above 650 psig, the switch will open and de-energize the outdoor unit. The switch will close again after the discharge pressure decreases to 460 psig. **NOTE:** When the switch opens and then closes, there will be a 3 minute short cycling delay before the outdoor unit will energize. Under normal conditions the switch is closed.

## REPLACEMENT PARTS

Replacement parts are available through all Nordyne distributors. Please have the complete model and serial number of the unit when ordering replacement parts.

### Electrical:

Capacitors	Temperature Limit Switches
Compressors	Thermostats
Contactors	Time Delay Relays
Pressure Switches	Transformers
Relays	

### Motors:

Blower Motor	Fan Motor
--------------	-----------

### Components:

Blower Assembly	Fan Grille
Cabinet Panels	Filter/Driers
Expansion Valves	

## UNIT DIMENSIONS

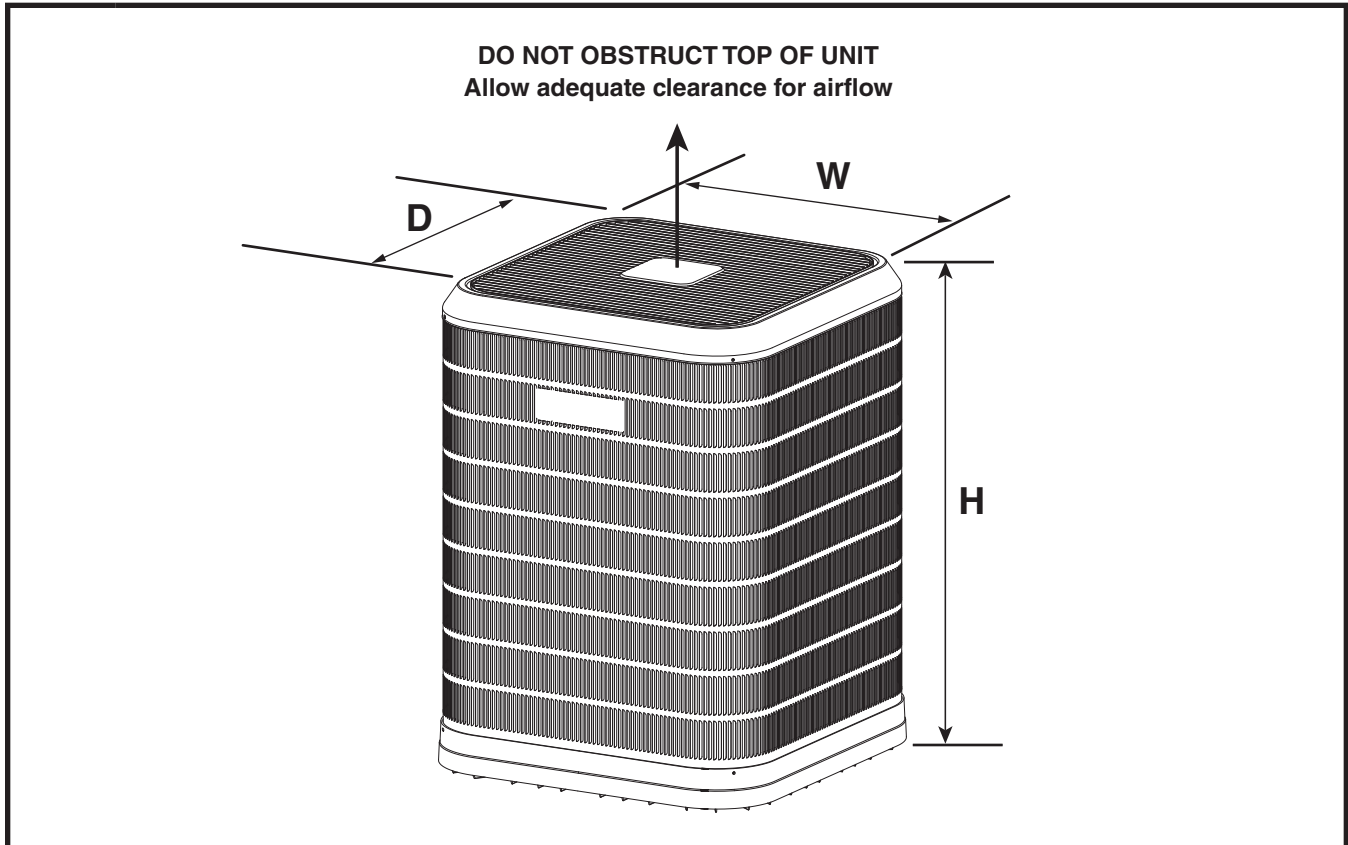

		STANDARD MODELS				PREMIUM / ULTRA PREMIUM MODELS	
2 TON		<b>DT4BF-024KA</b>	<b>ET4BF-024KA</b>	<b>JT4BF-024KA</b>	<b>MSH4BF-024KA</b>	<b>FT4BF-024KA</b>	<b>PSH4BF-024KA</b>
	H	43	43	43	43	45	45
	W	30 1/2	30 3/4	30 3/4	30 3/4	31 1/4	31 1/4
	D	30 1/2	30 3/4	30 3/4	30 3/4	31 1/4	31 1/4
3 TON		<b>DT4BF-036KA</b>	<b>ET4BF-036KA</b>	<b>JT4BF-036KA</b>	<b>MSH4BF-036KA</b>	<b>FT4BF-036KA</b>	<b>PSH4BF-036KA</b>
	H	43	43	43	43	45	45
	W	30 1/2	30 3/4	30 3/4	30 3/4	31 1/4	31 1/4
	D	30 1/2	30 3/4	30 3/4	30 3/4	31 1/4	31 1/4
4 TON		<b>DT4BF-048KA</b>	<b>ET4BF-048KA</b>	<b>JT4BF-048KA</b>	<b>MSH4BF-048KA</b>	<b>FT4BF-048KA</b>	<b>PSH4BF-048KA</b>
	H	43	43	43	43	45	45
	W	30 1/2	30 3/4	30 3/4	30 3/4	31 1/4	31 1/4
	D	30 1/2	30 3/4	30 3/4	30 3/4	31 1/4	31 1/4
5 TON		<b>DT4BF-060KA</b>	<b>ET4BF-060KA</b>	<b>JT4BF-060KA</b>	<b>MSH4BF-060KA</b>	<b>FT4BF-060KA</b>	<b>PSH4BF-060KA</b>
	H	43	43	43	43	45	45
	W	30 1/2	30 3/4	30 3/4	30 3/4	31 1/4	31 1/4
	D	30 1/2	30 3/4	30 3/4	30 3/4	31 1/4	31 1/4

**Figure 6. Unit Dimensions**

## COOLING CHARGING CHARTS

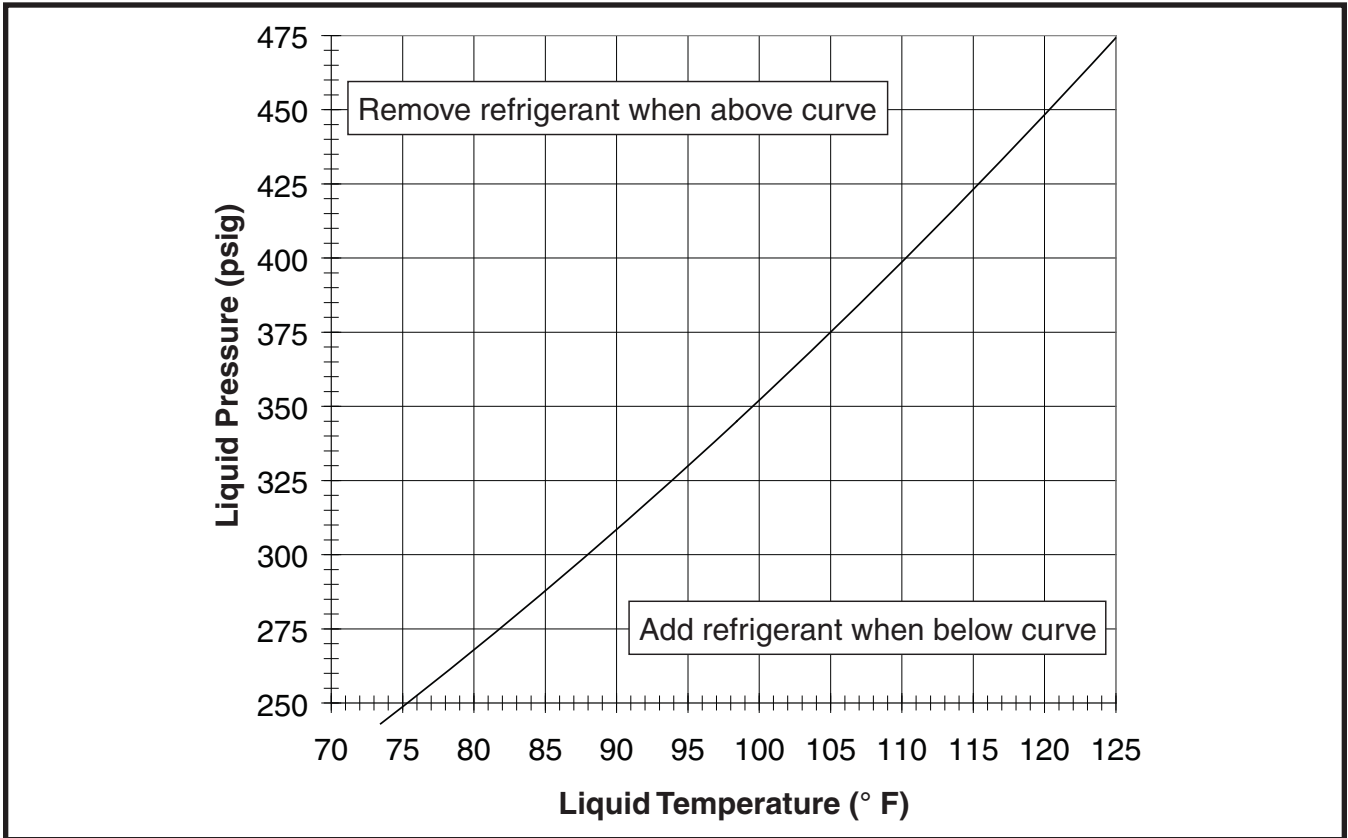

Figure 7. Charging Chart for 2 Ton Units

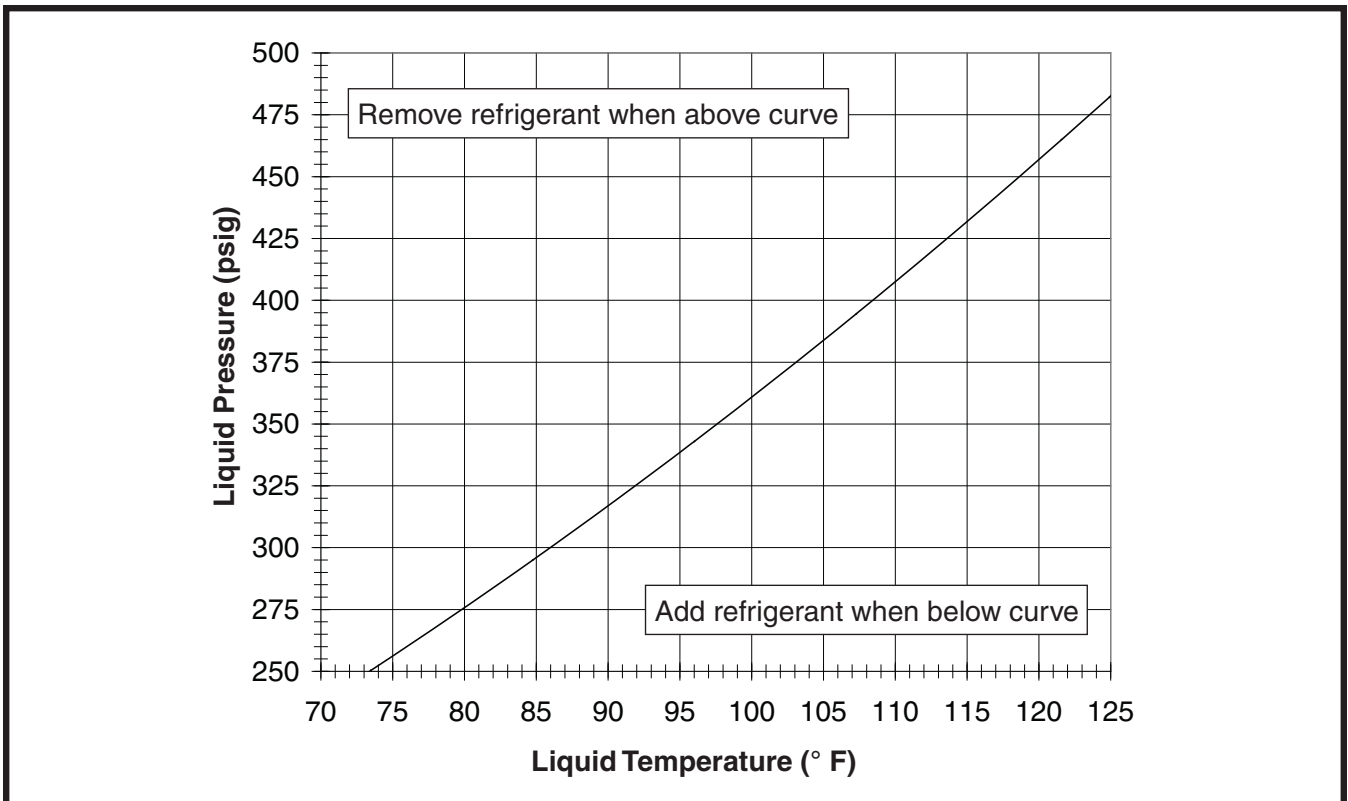

Figure 8. Charging Chart for 3 Ton Units

### COOLING CHARGING CHARTS (CONTINUED)

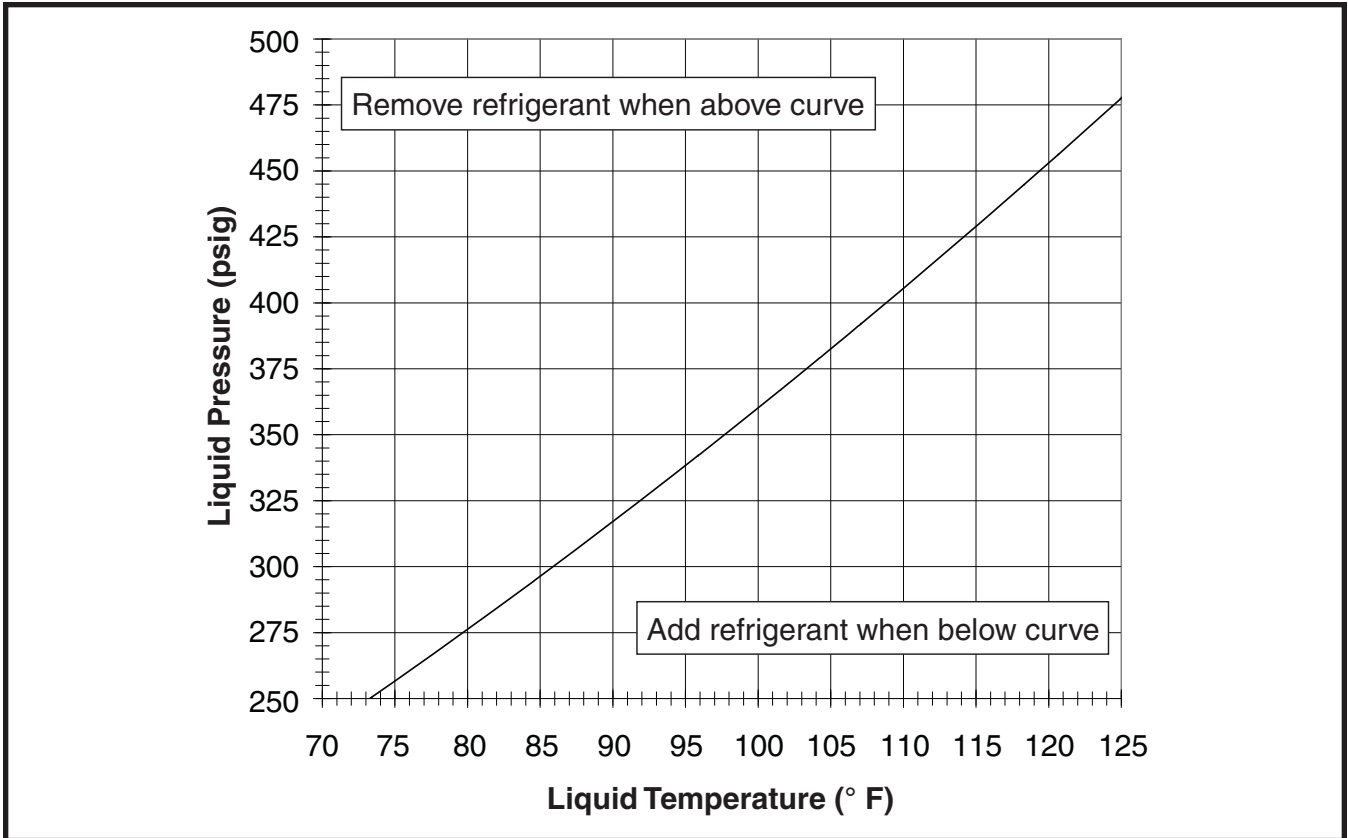

Figure 9. Charging Chart for 4 Ton Units

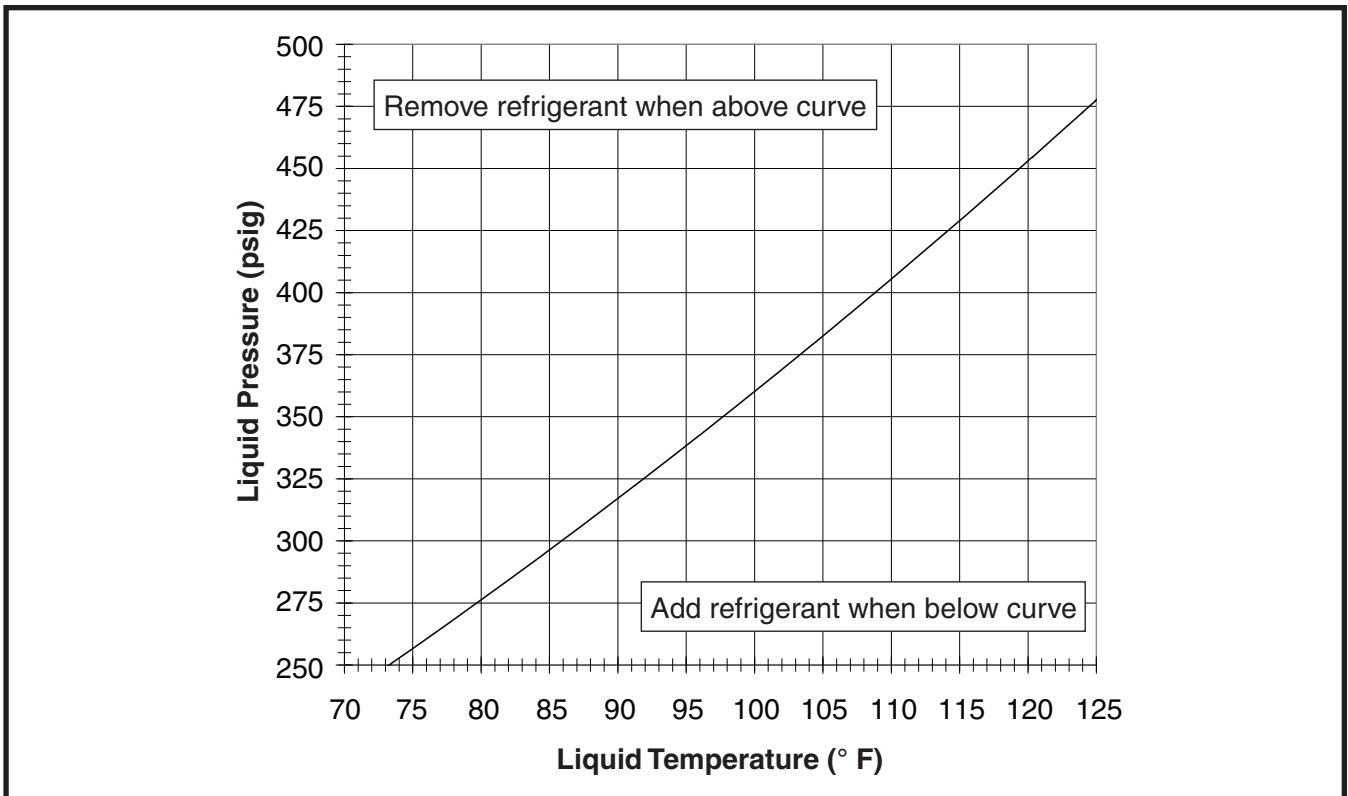

Figure 10. Charging Chart for 5 Ton Units

# HEATING CHARGING CHART

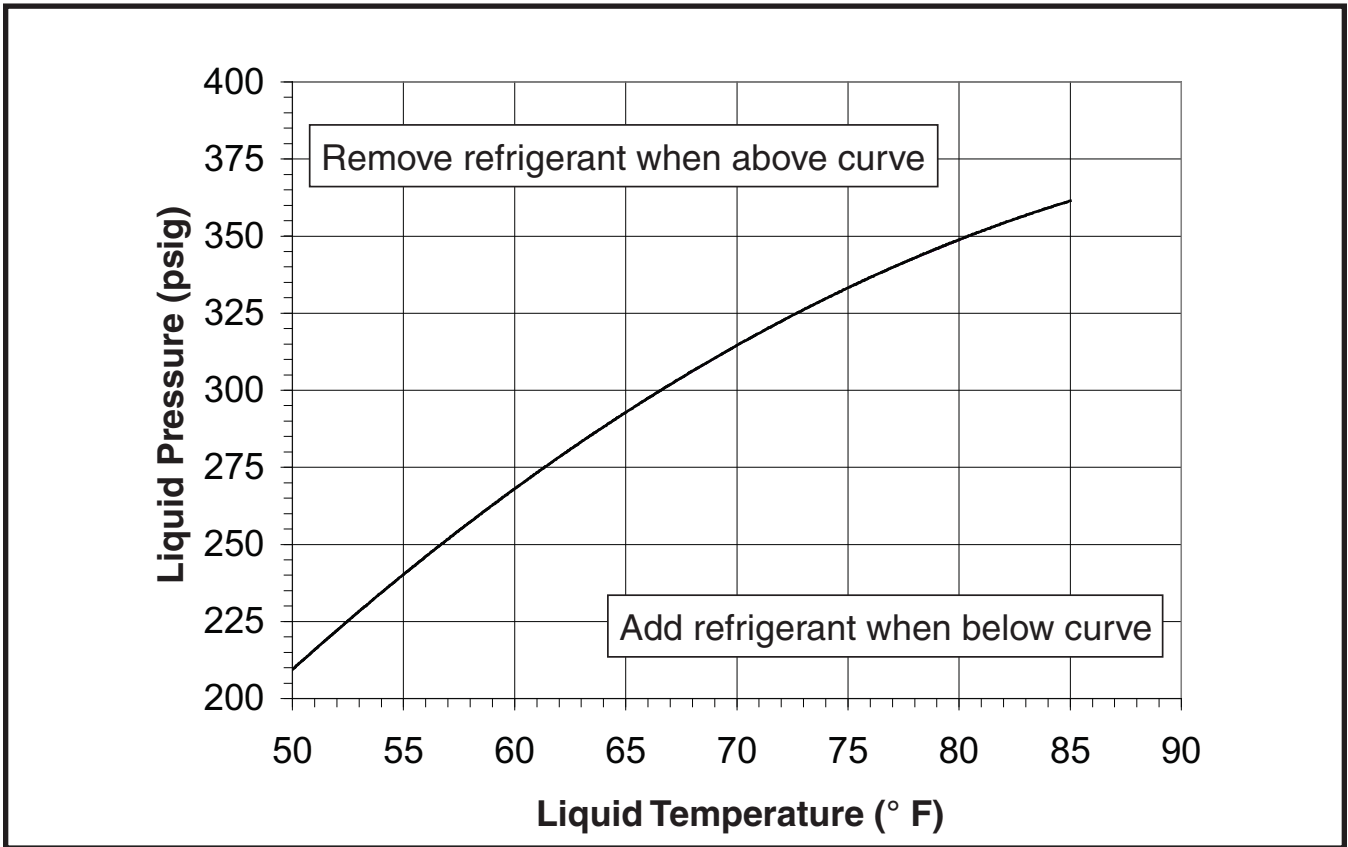

Figure 11. Heating Charging Chart

# WIRING DIAGRAM

**Two Stage Split System Heat Pump (Outdoor Section) With Demand Defrost and PSC Fan Motor 208/230V Single Phase / 60 Hz.**

**NOTES:**

1. Disconnect all power before servicing.
2. For supply connections use copper conductors only.
3. Not suitable on systems that exceed 150 volts to ground.
4. For replacement wires use conductors suitable for 105 deg C.
5. For ampacities and overcurrent protection, see unit rating plate.
6. Connect to 24 vac/40va/class 2 circuit. See furnace/air handler installation instructions for control circuit and optional relay/transformer kits.

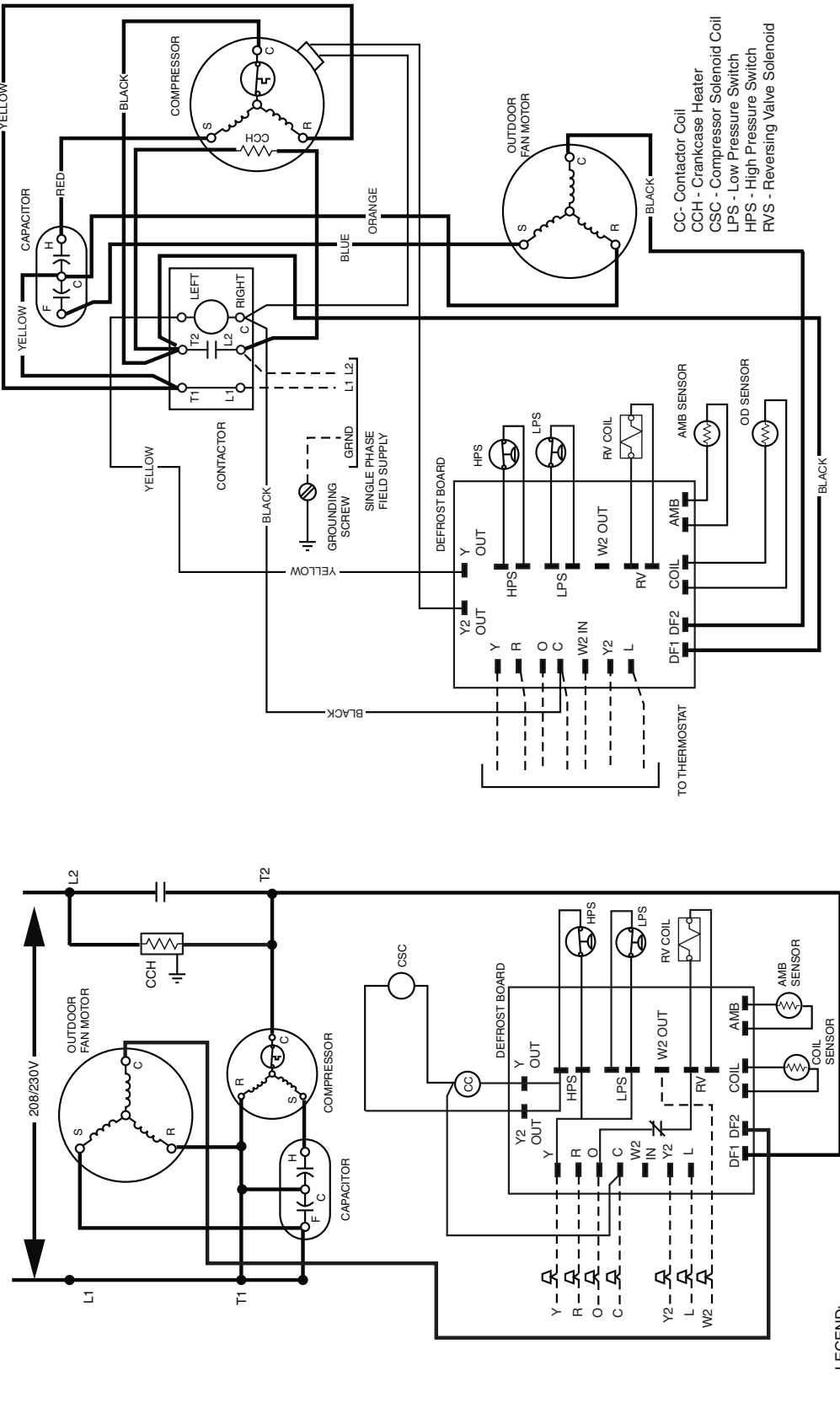

**LEGEND:**  
 FIELD WIRING ---  
 LOW VOLTAGE - - -  
 HIGH VOLTAGE ———



7111200

0410

**Figure 12. Wiring Diagram for 2 Ton Standard Models (DT4BF-024KA, ET4BF-024KA, JT4BF-024KA, MSH4BF-024KA)**



# WIRING DIAGRAM

## Two Stage Split System Heat Pump With Demand Defrost and Two Speed Fan Motor

208/230V Single Phase / 60 Hz.

- NOTES:
1. Disconnect all power before servicing.
  2. For supply connections use copper conductors only.
  3. Not suitable on systems that exceed 150 volts to ground.
  4. For replacement wires use conductors suitable for 105 °C
  5. For ampacities and overcurrent protection, see unit rating plate.
  6. Connect to 24 vac/40va/class 2 circuit. See furnace/airhandler installation instructions for control circuit and optional relay/transformer kits.

1. Couper le courant avant de faire leretien.
2. Employez uniquement des conducteurs en cuivre.
3. Ne convient pas aux installations de plus de 150 volt a la terre.

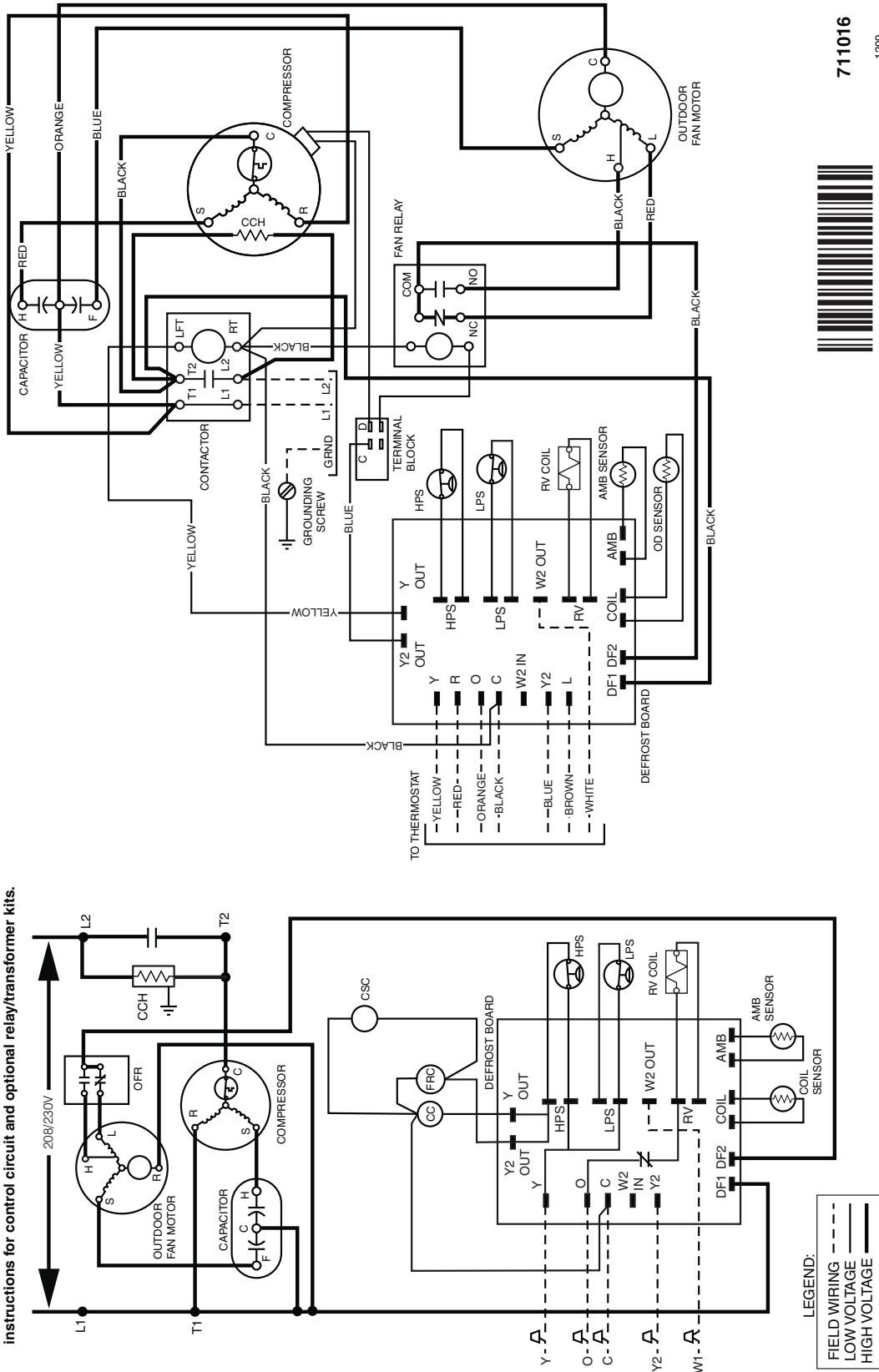

711016

1209

Figure 13. Wiring Diagram for 3 Ton Standard Models (DT4BF-036KA, ET4BF-036KA, JT4BF-036KA, MSH4BF-036KA)

# WIRING DIAGRAM

Two Stage Split System Heat Pump (Outdoor Section) With Demand Defrost and ECM Fan Motor 208/230V Single Phase / 60 Hz.

**NOTES:**

1. Disconnect all power before servicing.
2. For supply connections use copper conductors only.
3. Not suitable on systems that exceed 150 volts to ground.
4. For replacement wires use conductors suitable for 105 °C
5. For ampacities and overcurrent protection, see unit rating plate.
6. Connect to 24 vac/40va/class 2 circuit. See furnace/airhandler installation instructions for control circuit and optional relay/transformer kits.

1. Couper le courant avant de faire leretien.
2. Employez uniquement des conducteurs en cuivre.
3. Ne convient pas aux installations de plus de 150 volt a la terre.

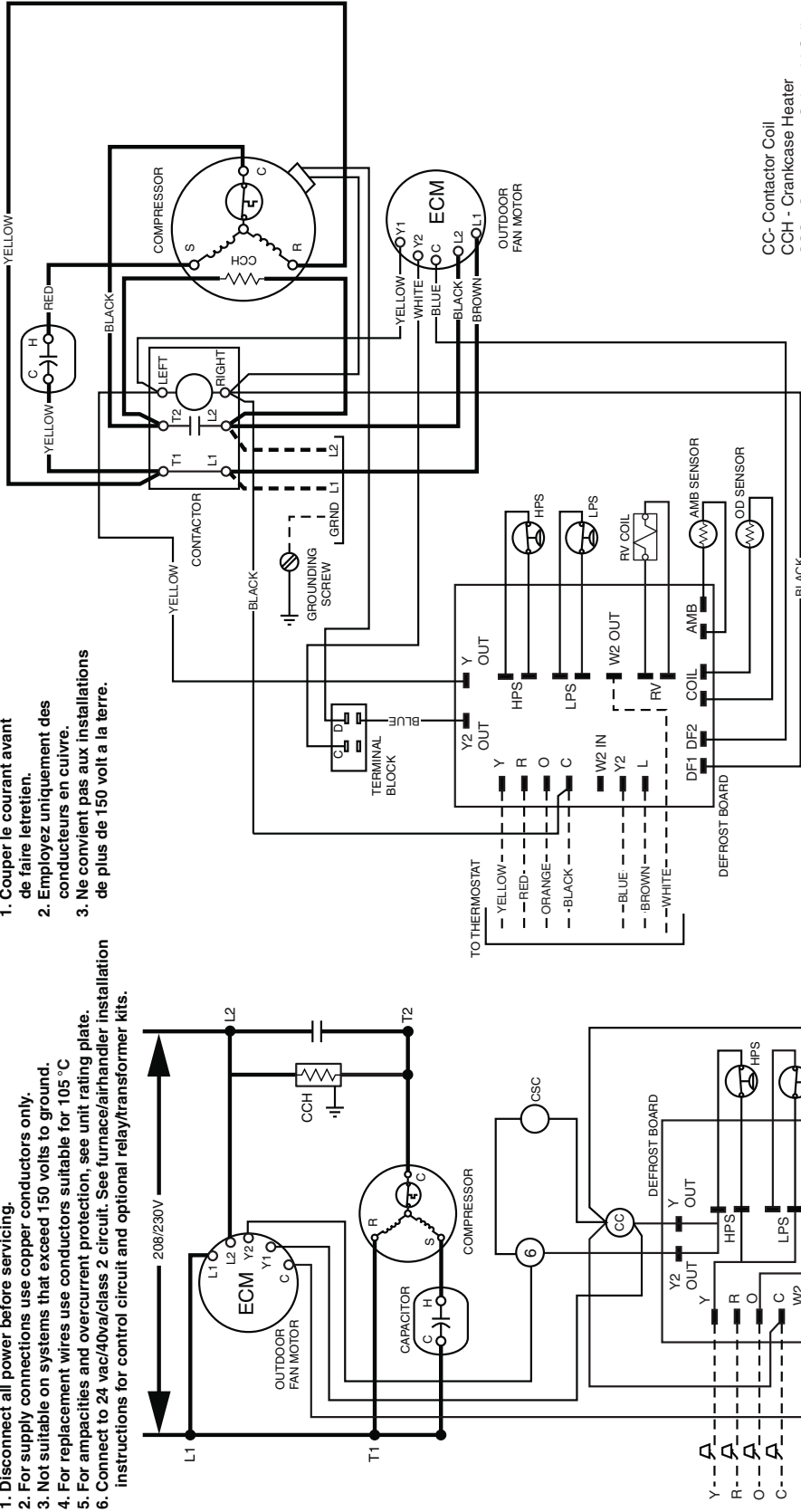

- CC - Contactor Coil
- CCH - Crankcase Heater
- CSC - Compressor Solenoid Coil
- LPS - Low Pressure Switch
- HPS - High Pressure Switch
- RVS - Reversing Valve Solenoid



711017A  
Replaces 7110170

0410

Figure 14. Wiring Diagram for 4 & 5 Ton Standard Models

(DT4BF-048KA, ET4BF-048KA, JT4BF-048KA, MSH4BF-048KA) - 4 Ton Models  
(DT4BF-060KA, ET4BF-060KA, JT4BF-060KA, MSH4BF-060KA) - 5 Ton Models

# WIRING DIAGRAM

Two Stage Split System Heat Pump (Outdoor Section) With Demand Defrost and ECM Fan Motor 208/230V Single Phase / 60 Hz.

## NOTES:

1. Disconnect all power before servicing.
2. For supply connections use copper conductors only.
3. Not suitable on systems that exceed 150 volts to ground.
4. For replacement wires use conductors suitable for 105 °C
5. For ampacities and overcurrent protection, see unit rating plate.
6. Connect to 24 vac/40vac class 2 circuit. See furnace/airhandler installation instructions for control circuit and optional relay/transformer kits.

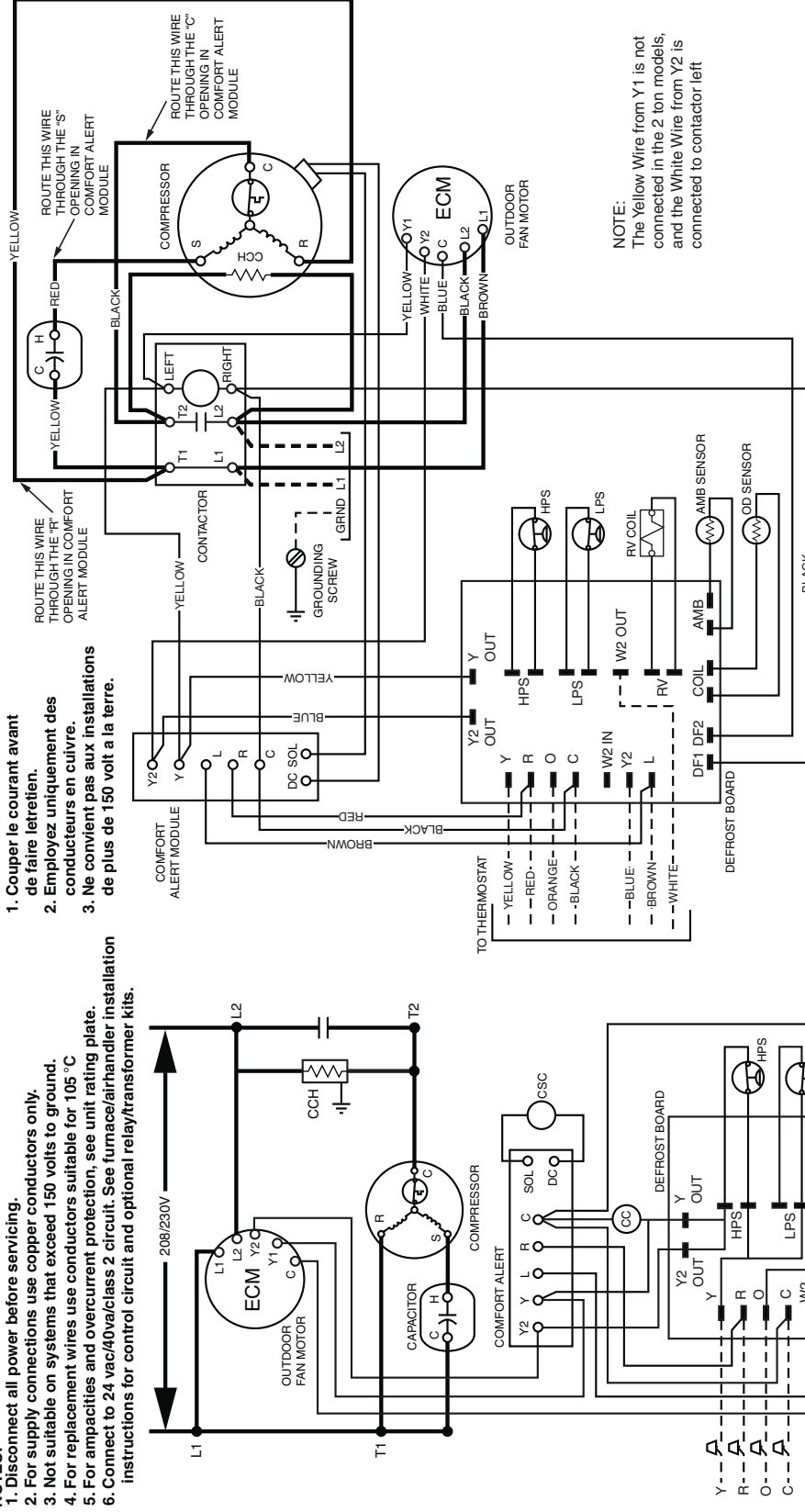

NOTE:  
The Yellow Wire from Y1 is not connected in the 2 ton models, and the White Wire from Y2 is connected to contactor left

Status LED	Status LED Description
Green "POWER"	Module has power
Red "TRIP"	Thermostat demand signal 'Y' is present, but the compressor is not running
Yellow "ALERT" Flash Code 1	LONG RUN TIME - Compressor is running extremely long run cycle
Yellow "ALERT" Flash Code 2	SYSTEM PRESSURE TRIP - Discharge or suction pressure out of limits or compressor overloaded
Yellow "ALERT" Flash Code 3	SHORT CYCLING - Compressor is running only briefly
Yellow "ALERT" Flash Code 4	LOCKED ROTOR
Yellow "ALERT" Flash Code 5	OPEN CIRCUIT
Yellow "ALERT" Flash Code 6	OPEN START CIRCUIT - Current only in run circuit
Yellow "ALERT" Flash Code 7	OPEN RUN CIRCUIT - Current only in start circuit
Yellow "ALERT" Flash Code 8	WELDED CONTACTOR - Compressor always runs
Yellow "ALERT" Flash Code 9	LOW VOLTAGE - Control circuit < 17VAC

- CC - Contactor Coil
- CCH - Crankcase Heater
- CSC - Compressor Solenoid Coil
- LPS - Low Pressure Switch
- HPS - High Pressure Switch
- RVS - Reversing Valve Solenoid



7109650

0609

Figure 15. Wiring Diagram for 2, 4, & 5 Ton Premium / Ultra Premium Models  
 (FT4BF-024KA, PSH4BF-024KA) - 2 Ton Models  
 (FT4BF-048KA, PSH4BF-048KA) - 4 Ton Models  
 (FT4BF-060KA, PSH4BF-060KA) - 5 Ton Models

# WIRING DIAGRAM

## Two Stage Split System Heat Pump With Demand Defrost and Two Speed Fan Motor

## 208/230V Single Phase / 60 Hz.

### NOTES:

1. Disconnect all power before servicing.
2. For supply connections use copper conductors only.
3. Not suitable on systems that exceed 150 volts to ground.
4. For replacement wires use conductors suitable for 105 °C
5. For ampacities and overcurrent protection, see unit rating plate.
6. Connect to 24 vac/40va/class 2 circuit. See furnace/airhandler installation instructions for control circuit and optional relay/transformer kits.

1. Couper le courant avant de faire l'entretien.
2. Employez uniquement des conducteurs en cuivre.
3. Ne convient pas aux installations de plus de 150 volt a la terre.

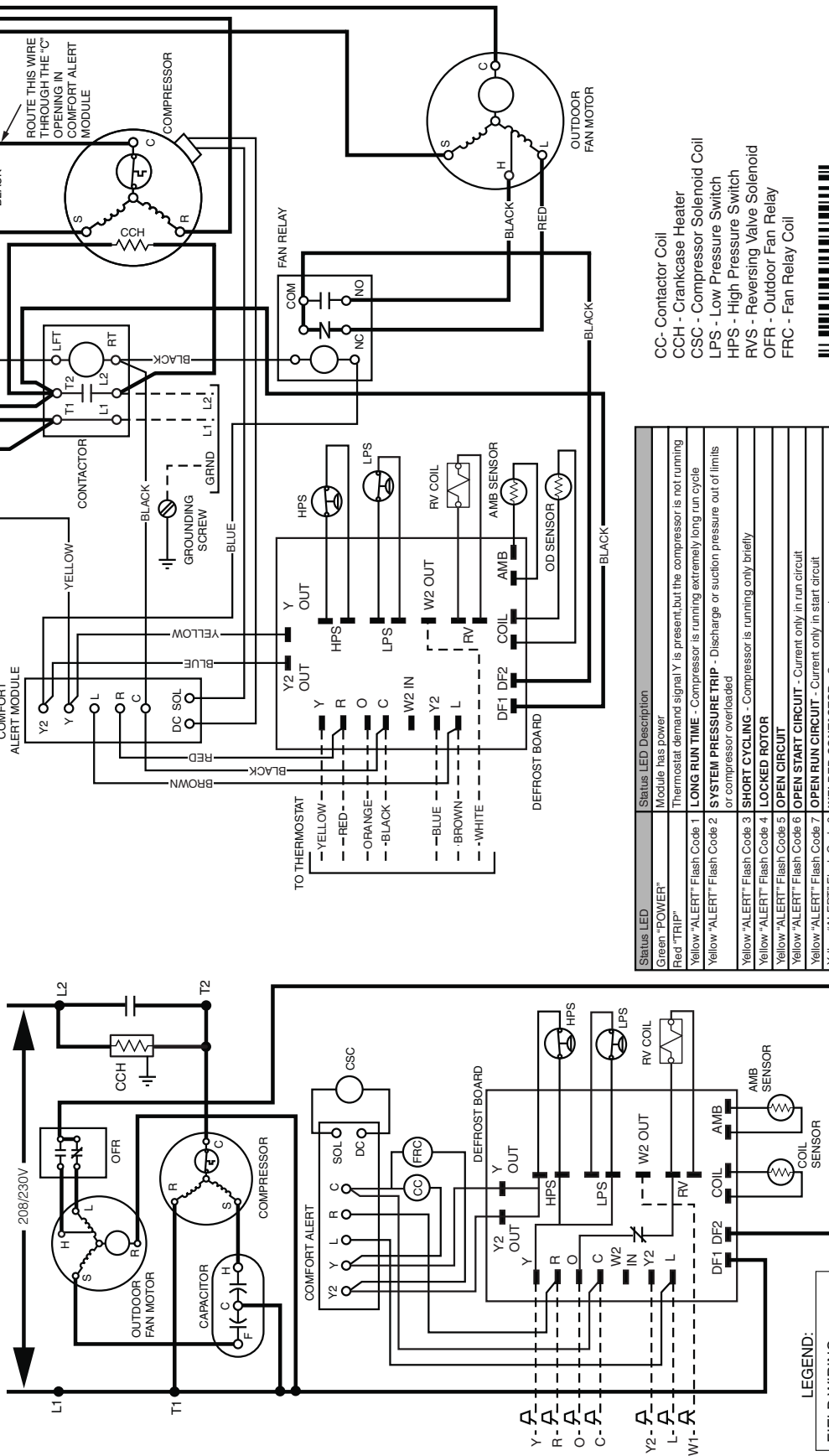

Status LED	Status LED Description
Green "POWER"	Module has power
Red "TRIP"	Thermostat demand signal Y is present but the compressor is not running
Yellow "ALERT" Flash Code 1	LONG RUN TIME - Compressor is running extremely long run cycle
Yellow "ALERT" Flash Code 2	SYSTEM PRESSURE TRIP - Discharge or suction pressure out of limits or compressor overloaded
Yellow "ALERT" Flash Code 3	SHORT CYCLING - Compressor is running only briefly
Yellow "ALERT" Flash Code 4	LOCKED ROTOR
Yellow "ALERT" Flash Code 5	OPEN CIRCUIT
Yellow "ALERT" Flash Code 6	OPEN START CIRCUIT - Current only in run circuit
Yellow "ALERT" Flash Code 7	OPEN RUN CIRCUIT - Current only in start circuit
Yellow "ALERT" Flash Code 8	WELDED CONTACTOR - Compressor always runs
Yellow "ALERT" Flash Code 9	LOW VOLTAGE - Control circuit < 17 VAC

- CC - Contactor Coil
- CCH - Crankcase Heater
- CSC - Compressor Solenoid Coil
- LPS - Low Pressure Switch
- HPS - High Pressure Switch
- RVS - Reversing Valve Solenoid
- OFR - Outdoor Fan Relay
- FRC - Fan Relay Coil



7109640

0809

Figure 16. Wiring Diagram for 3 Ton Premium / Ultra Premium Models (FT4BF-036KA, PSH4BF-036KA)

## COMFORT ALERT TROUBLESHOOTING

Status LED	Status LED Description	Status LED Troubleshooting Information
POWER (Green LED)	Module has power	Supply voltage is present at module terminals
TRIP (Red LED)	Thermostat demand signal Y is present, but compressor is not running	<ul style="list-style-type: none"> <li>• Compressor protector is open</li> <li>• Check for high head pressure</li> <li>• Check compressor supply voltage</li> <li>• Outdoor unit power disconnect is open</li> <li>• Compressor circuit breaker or fuse(s) is open</li> <li>• Broken wire or connector is not making contact</li> <li>• Low pressure switch open if present in system</li> <li>• Compressor contactor has failed open</li> </ul>
ALERT Flash Code 1 (Yellow LED)	Long Run Time Compressor is running extremely long run cycles	<ul style="list-style-type: none"> <li>• Low refrigerant charge</li> <li>• Evaporator blower is not running                             <ul style="list-style-type: none"> <li>— Check blower relay coil and contacts</li> <li>— Check blower motor capacitor</li> <li>— Check blower motor for failure or blockage</li> <li>— Check evaporator blower wiring and connectors</li> <li>— Check indoor blower control board</li> <li>— Check thermostat wiring for open circuit</li> </ul> </li> <li>• Evaporator coil is frozen                             <ul style="list-style-type: none"> <li>— Check for low suction pressure</li> <li>— Check for excessively low thermostat setting</li> <li>— Check evaporator airflow (coil blockages or return airfilter)</li> <li>— Check ductwork or registers for blockage</li> </ul> </li> <li>• Faulty metering device                             <ul style="list-style-type: none"> <li>— Check TXV bulb installation (size, location and contact)</li> <li>— Check if TXV/fixed orifice is stuck closed or defective</li> </ul> </li> <li>• Condenser coil is dirty</li> <li>• Liquid line restriction (filter drier blocked if present in system)</li> <li>• Thermostat is malfunctioning                             <ul style="list-style-type: none"> <li>— Solenoid plug not connected</li> <li>— Y2 not wired at Comfort Alert</li> <li>— Check thermostat sub-base or wiring for short circuit</li> <li>— Check thermostat installation (location, level)</li> </ul> </li> <li>• Comfort Alert failure</li> </ul>
ALERT Flash Code 2 (Yellow LED)	System Pressure Trip	<ul style="list-style-type: none"> <li>• High head pressure                             <ul style="list-style-type: none"> <li>— Check high pressure switch if present in system</li> <li>— Check if system is overcharged with refrigerant</li> <li>— Check for non-condensable in system</li> </ul> </li> </ul>
	Discharge or suction	<ul style="list-style-type: none"> <li>• Condenser coil poor air circulation (dirty, blocked, damaged)</li> </ul>
	pressure out of limits	<ul style="list-style-type: none"> <li>• Condenser fan is not running                             <ul style="list-style-type: none"> <li>— Check fan capacitor</li> <li>— Check fan wiring and connectors</li> <li>— Check fan motor for failure or blockage</li> </ul> </li> </ul>
	compressor overloaded	<ul style="list-style-type: none"> <li>• Return air duct has substantial leakage</li> <li>• If low pressure switch present in system, check Flash Code 1 information</li> </ul>

**Table 4. LED Diagnostics**

## COMFORT ALERT TROUBLESHOOTING - CONTINUED

Status LED	Status LED Description	Status LED Troubleshooting Information
ALERT Flash Code 3 (Yellow LED)	Short Cycling / Compressor is running only briefly	<ul style="list-style-type: none"> <li>• Thermostat demand signal is intermittent</li> <li>• Low line voltage (contact utility if voltage at disconnect is low)</li> <li>• Excessive liquid refrigerant in compressor</li> <li>• Compressor bearings are seized</li> </ul>
ALERT Flash Code 4 (Yellow LED)	Locked Rotor	<ul style="list-style-type: none"> <li>• Run capacitor has failed</li> <li>• Low line voltage (contact utility if voltage at disconnect is low)</li> <li>• Check wiring connections</li> <li>• Excessive liquid refrigerant in compressor</li> <li>• Compressor bearings are seized</li> <li>• Measure compressor oil level</li> </ul>
ALERT Flash Code 5 (Yellow LED)	Open Circuit	<ul style="list-style-type: none"> <li>• Outdoor unit power disconnect is open</li> <li>• Compressor circuit breaker or fuse(s) is open</li> <li>• Compressor contactor has failed open                             <ul style="list-style-type: none"> <li>— Check compressor contactor wiring and connectors</li> <li>— Check for compressor contactor failure (burned, pitted or open)</li> <li>— Check wiring and connectors between supply and compressor</li> <li>— Check for low pilot voltage at compressor contactor coil</li> <li>— High pressure switch is open and requires manual reset</li> </ul> </li> <li>• Open circuit in compressor supply wiring or connections</li> <li>• Unusually long compressor protector reset time due to extreme ambient temperature</li> <li>• Compressor windings are damaged                             <ul style="list-style-type: none"> <li>— Check compressor motor winding resistance</li> </ul> </li> </ul>
ALERT Flash Code 6 (Yellow LED)	Open Start Circuit Current only in run circuit	<ul style="list-style-type: none"> <li>• Run capacitor has failed</li> <li>• Open circuit in compressor start wiring or connections                             <ul style="list-style-type: none"> <li>— Check wiring and connectors between supply and the compressor <b>S</b> terminal</li> </ul> </li> <li>• Compressor start winding is damaged                             <ul style="list-style-type: none"> <li>— Check compressor motor winding resistance</li> </ul> </li> </ul>
ALERT Flash Code 7 (Yellow LED)	Open run circuit Current only in start circuit	<ul style="list-style-type: none"> <li>• Open circuit in compressor run wiring or connections                             <ul style="list-style-type: none"> <li>— Check wiring and connectors between supply and the compressor <b>R</b> terminal</li> </ul> </li> <li>• Compressor run winding is damaged                             <ul style="list-style-type: none"> <li>— Check compressor motor winding resistance</li> </ul> </li> </ul>
ALERT Flash Code 8 (Yellow LED)	Welded Contactor Compressor always runs	<ul style="list-style-type: none"> <li>• Compressor contactor has failed closed</li> <li>• Thermostat demand signal not connected to module</li> </ul>
ALERT Flash Code 9 (Yellow LED)	Low Voltage Control circuit < 17VAC	<ul style="list-style-type: none"> <li>• Control circuit transformer is overloaded</li> <li>• Low line voltage (contact utility if voltage at disconnect is low)</li> <li>• Check wiring connections</li> </ul>
<p>* Flash code number corresponds to a number of LED flashes, followed by a pause and then repeated. Trip and alert LED's flashing at same time means control circuit voltage is too low for operation.</p>		

**Table 4. LED Diagnostics - Continued**

## COMFORT ALERT TROUBLESHOOTING - CONTINUED

Miswired Module Indication	Recommended Troubleshooting Action
Green LED is not on, module does not power up	<ul style="list-style-type: none"> <li>• Determine if both <b>R</b> &amp; <b>C</b> module terminals are connected.</li> <li>• Verify voltage is present at module's <b>R</b> &amp; <b>C</b> terminals.</li> </ul>
Green LED intermittent, module powers up only when compressor runs	<ul style="list-style-type: none"> <li>• Determine if <b>R</b> &amp; <b>Y</b> terminals are wired in reverse.</li> <li>• Verify modules <b>R</b> and <b>C</b> terminals have a constant source.</li> </ul>
Trip LED is on, but system and compressor check OK	<ul style="list-style-type: none"> <li>• Verify <b>Y</b> terminal is connected to 24VAC at contactor coil.</li> <li>• Verify voltage at contactor coil falls below 0.5VAC when off.</li> <li>• Verify 24VAC is present across <b>Y</b> &amp; <b>C</b> when thermostat demand signal is present. If not, <b>R</b> &amp; <b>C</b> are reversed wired.</li> </ul>
TRIP LED and ALERT LED flashing together	<ul style="list-style-type: none"> <li>• Verify <b>R</b> and <b>C</b> terminals are supplied with 19 - 28VAC.</li> </ul>
ALERT Flash CODE 3 displayed incorrectly (Compressor short cycling)	<ul style="list-style-type: none"> <li>• Verify <b>Y</b> terminal is connected to 24VAC at contactor coil.</li> <li>• Verify voltage at contactor coil falls below 0.5VAC when off.</li> </ul>
ALERT Flash Code 5, 6, or 7 displayed incorrectly (Open Circuit, Open Start Circuit or Open Run Circuit)	<ul style="list-style-type: none"> <li>• Verify the compressor run and start wires are routed through the module's current sensing holes.</li> <li>• Verify the <b>Y</b> terminal is connected to 24VAC at contactor coil.</li> <li>• Verify voltage at contactor coil falls below 0.5VAC when off.</li> </ul>
ALERT Flash Code 6 (Open Start Circuit) displayed for Code 7 (Open Run Circuit) or vice-versa	<ul style="list-style-type: none"> <li>• Verify the compressor run and start wires are routed through the correct module sensing holes.</li> </ul>
ALERT Flash Code 8 displayed incorrectly (Welded Contactor)	<ul style="list-style-type: none"> <li>• Determine if module's <b>Y</b> terminal is connected.</li> <li>• Verify <b>Y</b> terminal is connected to 24VAC at contactor coil.</li> <li>• Verify 24VAC is present across <b>Y</b> &amp; <b>C</b> when thermostat demand signal is present. If not, <b>R</b> and <b>C</b> are reversed wired.</li> <li>• Verify voltage at contactor coil falls below 0.5VAC when off.</li> <li>• Review Thermostat Demand Wiring (page 10) for <b>Y</b> &amp; <b>C</b> wiring.</li> </ul>

**Table 5. Module Wiring Troubleshooting**

**INSTALLER: PLEASE LEAVE THESE  
INSTALLATION INSTRUCTIONS WITH  
THE HOMEOWNER.**



**NORDYNE**  
COMPLETE COMFORT. GENUINE VALUE.

Specifications & illustrations subject to change without notice or incurring obligations.  
O' Fallon, MO | Printed in U.S.A. (09/10)

708868B

708868B (Replaces 708868A)